



**ROCHESTER
GAUGES, INC.**

ISO 9001:2008 CERTIFIED

Magnetel™ Rough Rider™ Liquid-Level Gauges

M6300

Application

The M6300 series Magnetel™ Rough Rider™ gauges were designed to withstand the vibration and shock inherent in mobile service. Their service life in over-the-road and off-road transports, carrying liquids ranging from LP-gas to crude oil, is unsurpassed. These gauges allow a continuous reading between 5% and 95% of tank contents.

General Information & Features*

The Magnetel™ Rough Rider™ gauges are to be installed in the side or end of mobile tanks at the centerline. They are equipped with an exclusive spring controlled shock absorber on the float arm which substantially reduces the stress that quickly destroys conventional gauges. Angle mounting gauges are also available.

The M6339 incorporates a 4" [100 mm] dial and the 6342 incorporates an 8" [200 mm] dial. When necessary, the dials are easily replaceable. Refer to price list P6300 for available types, part numbers, etc., as well as other replacement parts and accessories.

Price list M6300 includes information on materials of construction, available options, and sales and pricing policy.

The Magnetel™ Rough Rider™ gauges are designed for working pressures ranging from atmospheric to 450 [31 Bar] psig.

* Materials and specifications are subject to change without notice.
Pressure ratings subject to change due to temperature and other environmental considerations.



**Magnetel™ Rough Rider™
Liquid-Level Gauges**

01/20/10

See reverse side for dimensional data, materials of construction, performance, and advice on how to order.

The Measure of Excellence

M6300

[METRIC]

Magnetel™ Rough Rider™ Liquid-Level Gauges

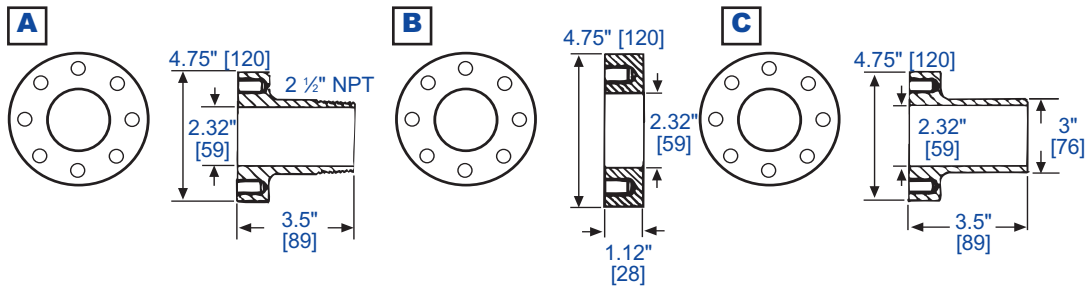
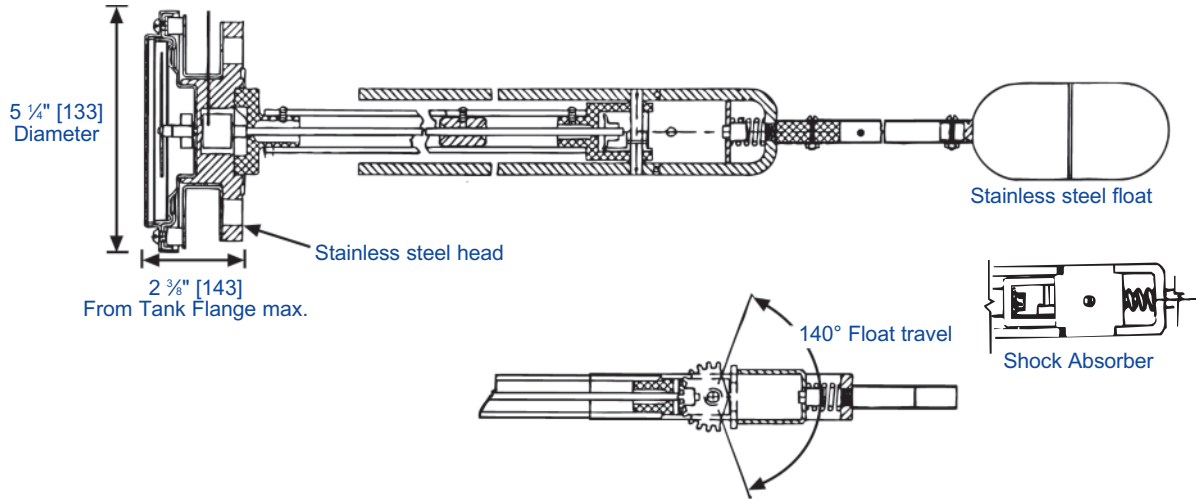

3.5" [89] Bolt Circle Adapters for Magnetel™ Gauges

Rochester Machining Standard MS-508 - See Rochester 22 Series

Part #	Mates With	Type	Material	Thread	Dimensions
0022-00029	6300 Series	2 1/2" NPT	Forged Steel	1/2"-13UNC-2B	Reference dwg. A
0022-00030		Welding			Reference dwg. B
0022-00500					Reference dwg. C

When Ordering, Specify:

1. Liquid to be gauged and specific gravity.
2. Inside diameter of tank heads, ellipsoidal, semi-ellipsoidal or hemispherical.
3. Complete model number desired from price list 6300, (example M6342-11).
4. Prefix letters for available options from price list 6300.
5. If a dial other than standard is required, furnish drawing and/or details.
6. Furnish tank drawings whenever ordering gauges for angle-mounting or for installation in vertical tanks.
7. If tank mounting flange is required, order separately from chart above.

01/20/10